



(19) **United States**

(12) **Patent Application Publication**
JEON et al.

(10) **Pub. No.: US 2018/0254310 A1**

(43) **Pub. Date: Sep. 6, 2018**

(54) **ORGANIC LIGHT EMITTING DIODE
DISPLAY DEVICE AND METHOD OF
FABRICATING THE SAME**

Publication Classification

(51) **Int. Cl.**
H01L 27/32 (2006.01)
H01L 51/56 (2006.01)
H01L 51/00 (2006.01)
(52) **U.S. Cl.**
CPC *H01L 27/3246* (2013.01); *H01L 51/56*
(2013.01); *H01L 51/0005* (2013.01); *H01L*
27/326 (2013.01); *H01L 27/3258* (2013.01);
H01L 27/3262 (2013.01)

(71) Applicant: **LG DISPLAY CO., LTD.**, Seoul (KR)

(72) Inventors: **Hong-Myeong JEON**, Goyang-si (KR);
Jae-Ki LEE, Paju-si (KR); **Hwang-Un**
SEO, Paju-si (KR); **A-Ryoung LEE**,
Seoul (KR); **Geum-Young LEE**,
Incheon (KR)

(21) Appl. No.: **15/974,496**

(22) Filed: **May 8, 2018**

Related U.S. Application Data

(62) Division of application No. 13/972,221, filed on Aug.
21, 2013, now Pat. No. 9,991,321.

Foreign Application Priority Data

Nov. 20, 2012 (KR) 10-2012-0131546

(57) **ABSTRACT**

An organic light emitting diode display device includes a first substrate including a display region, wherein a plurality of pixel regions are defined in the display region; a first electrode over the substrate and in each of the plurality of pixel regions; a bank on edges of the first electrode and surrounding each of the plurality of pixel regions, the bank including a lower layer having a hydrophilic property and an upper layer having a hydrophobic property; an organic emitting layer on the first electrode and in each of the plurality of pixel regions surrounded by the bank; and a second electrode on the organic emitting layer and covering an entire surface of the display region.

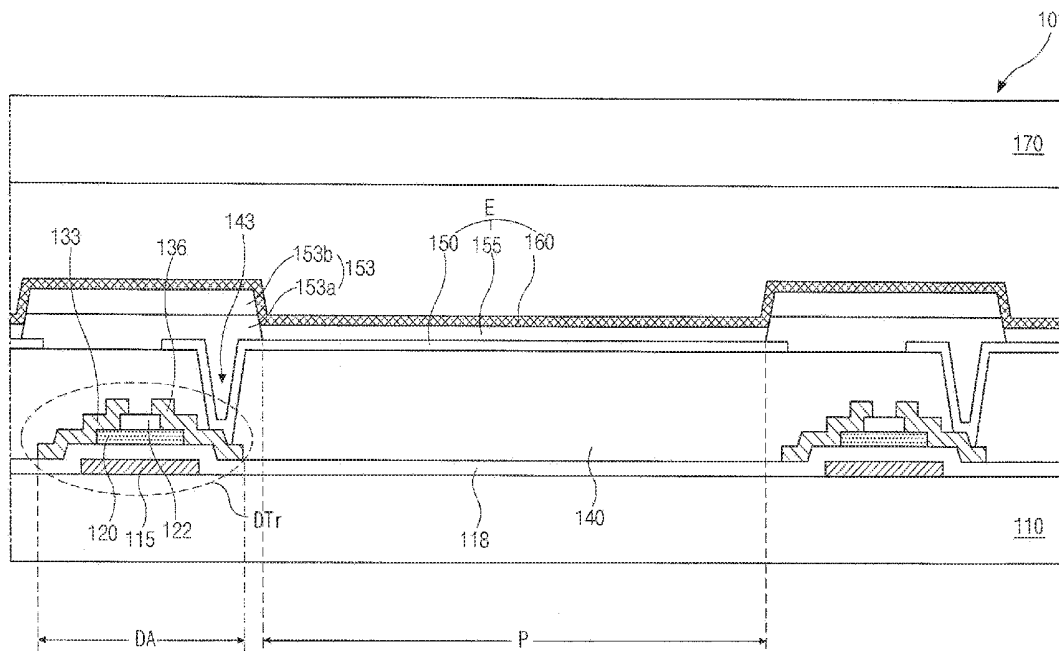

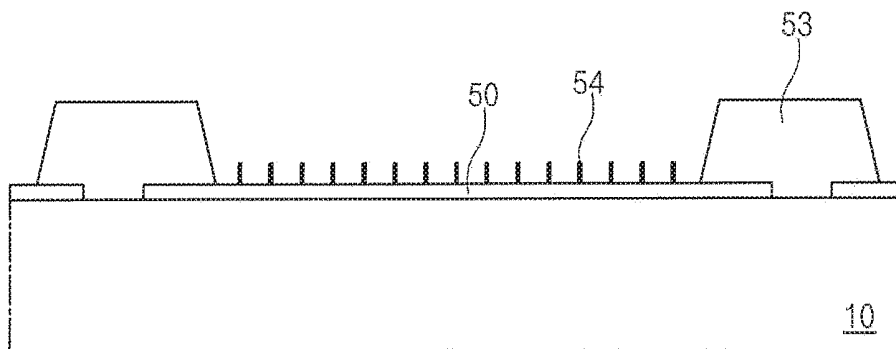

FIG. 1A
Related Art

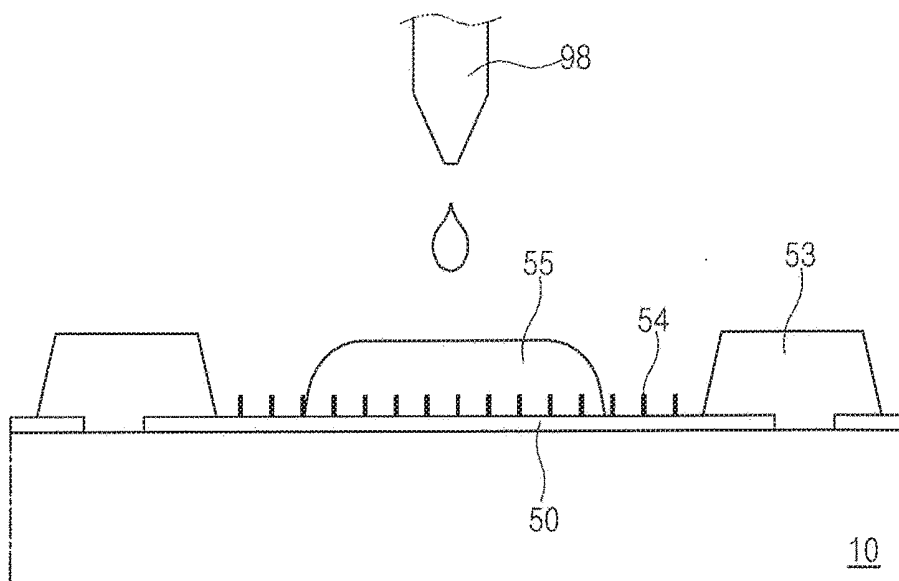

FIG. 1B
Related Art

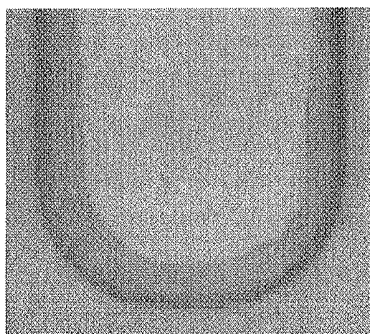

FIG. 2
Related Art

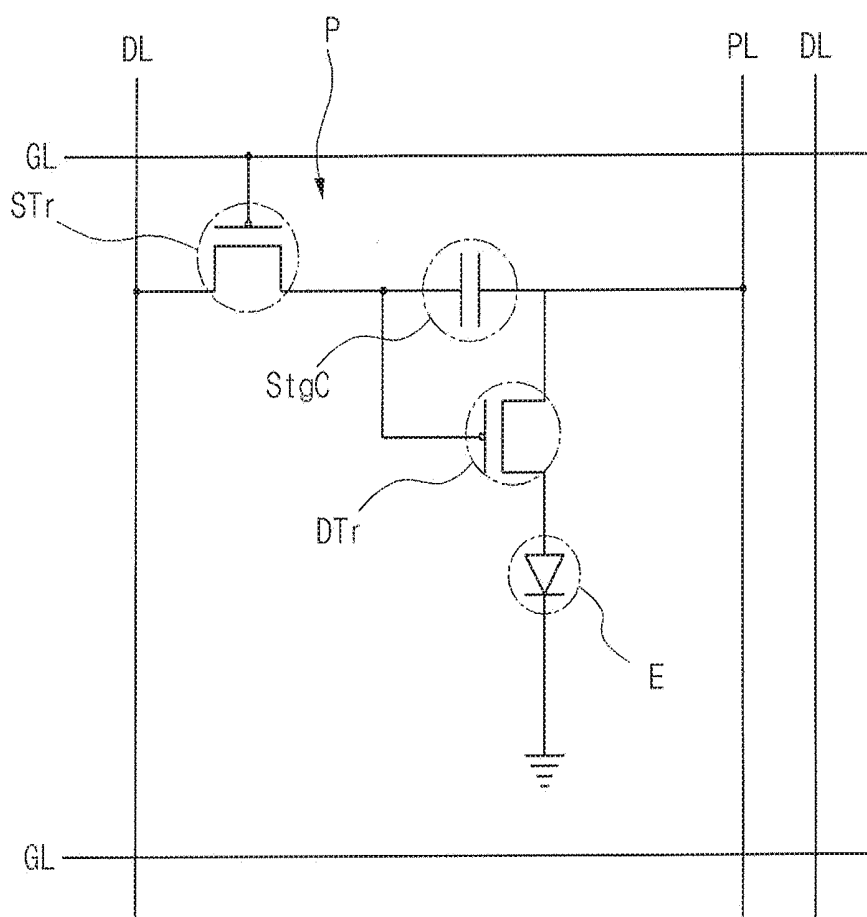

FIG. 3

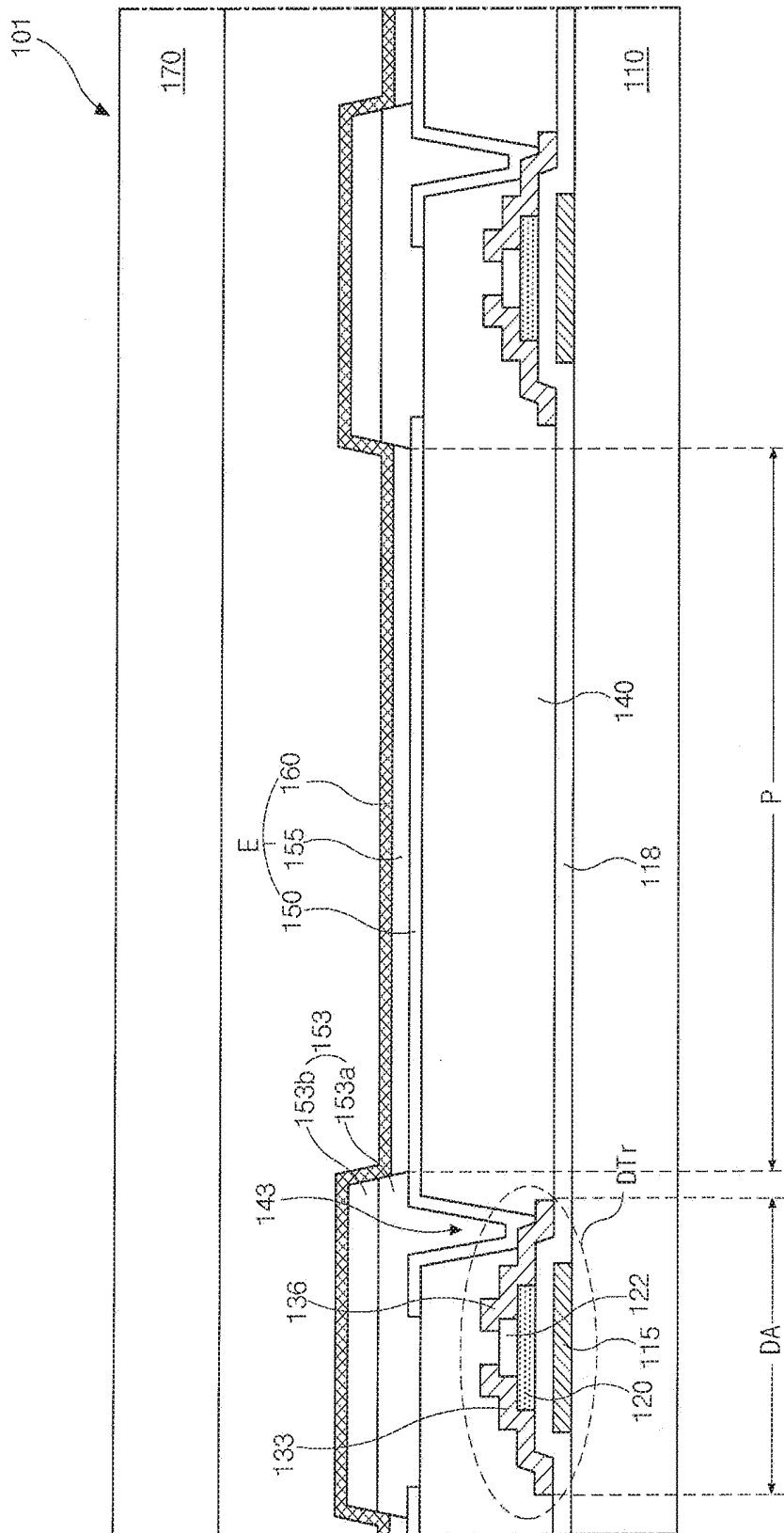

FIG. 4

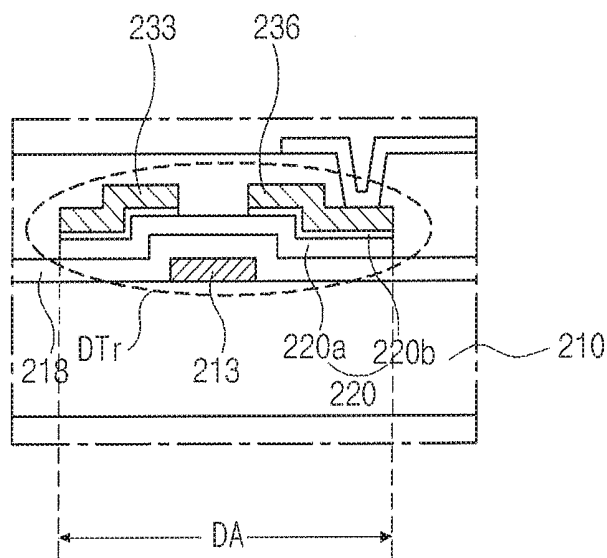

FIG. 5

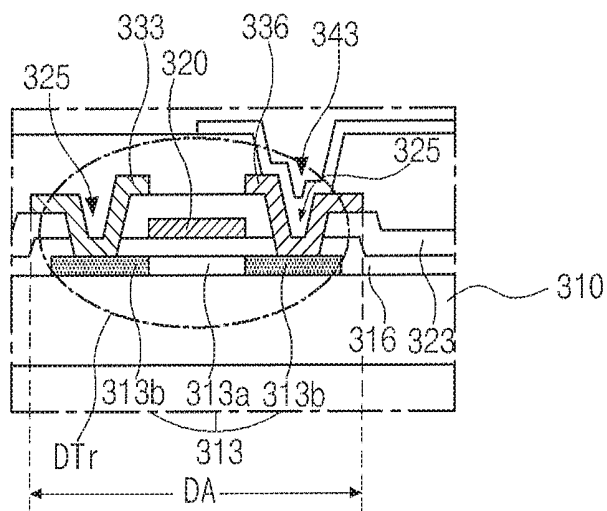

FIG. 6

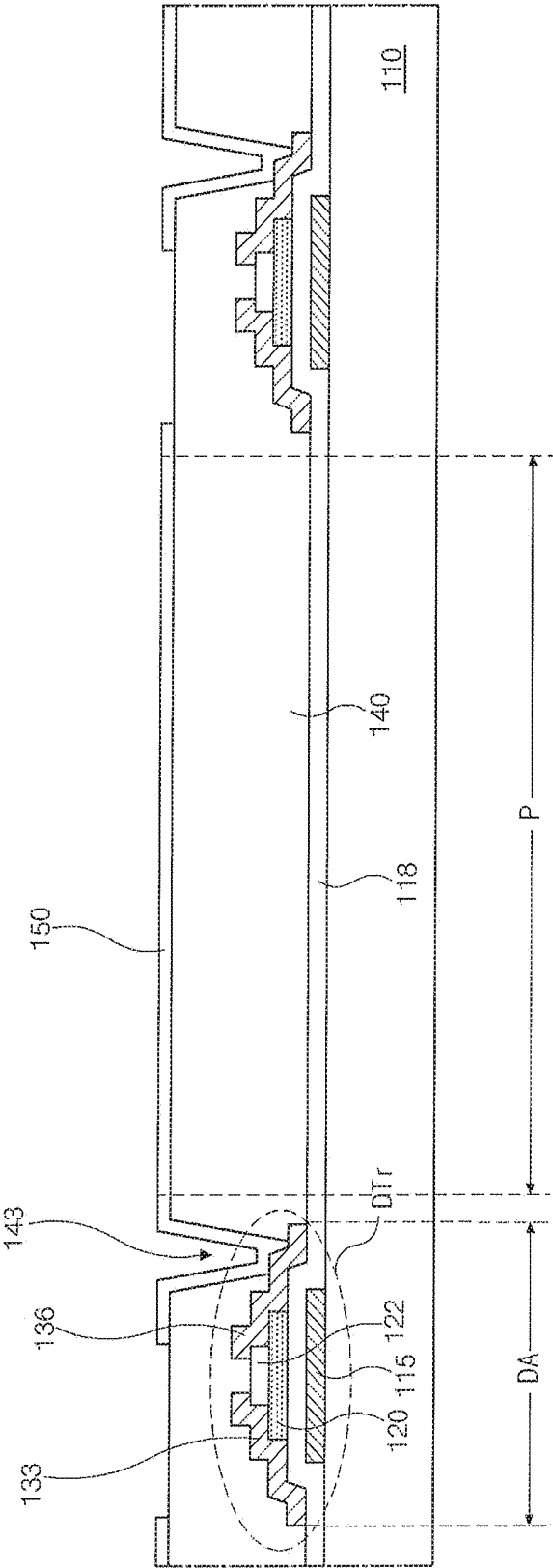

FIG. 7A

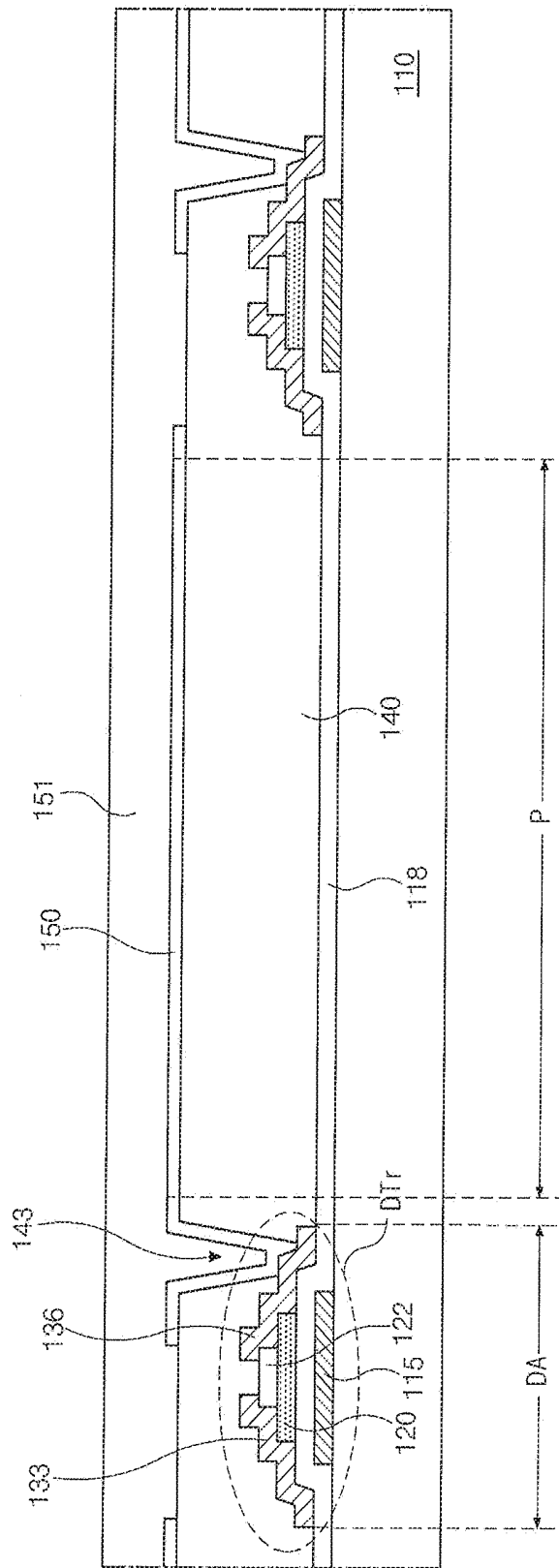

FIG. 7B

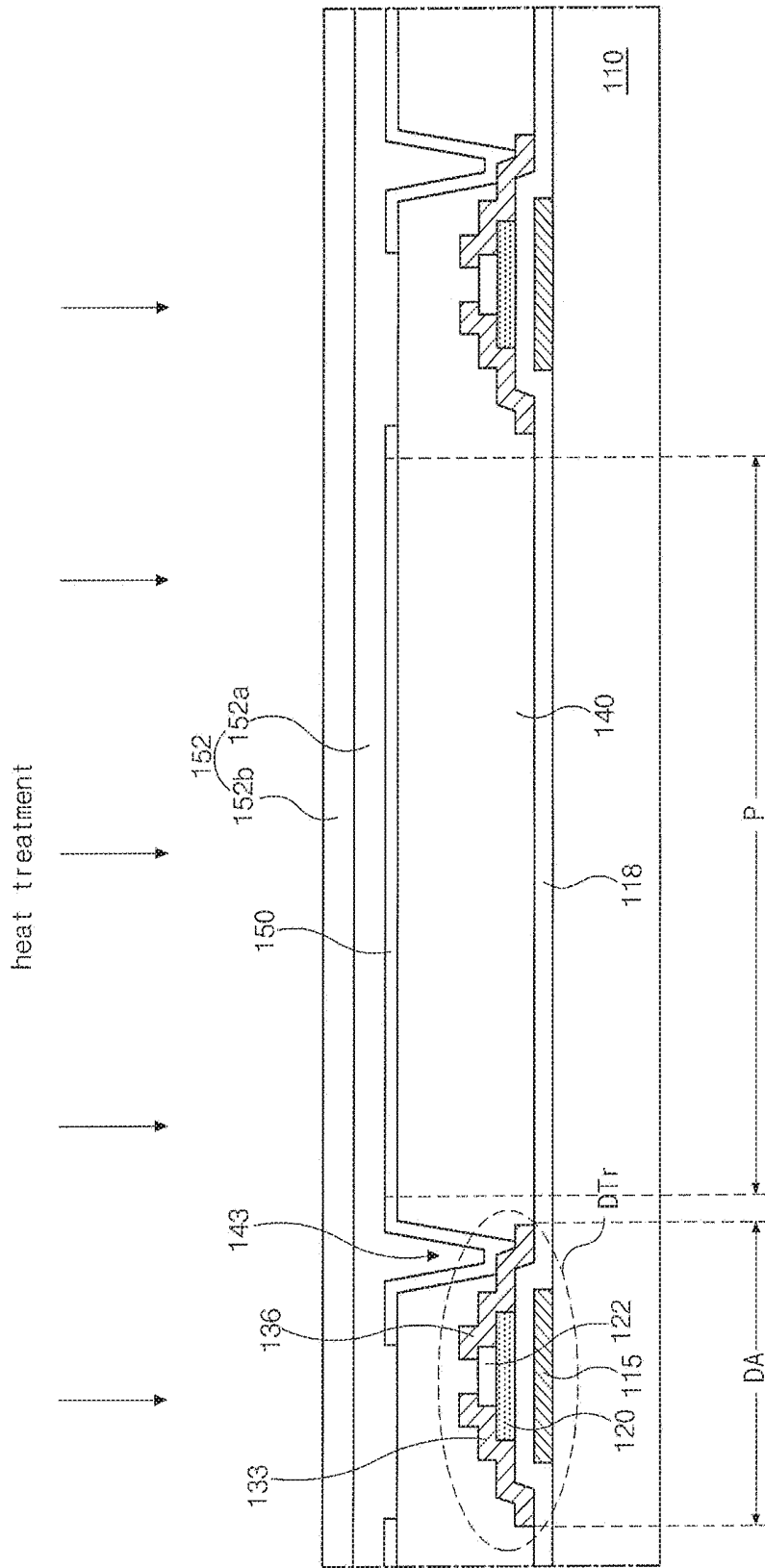

FIG. 7C

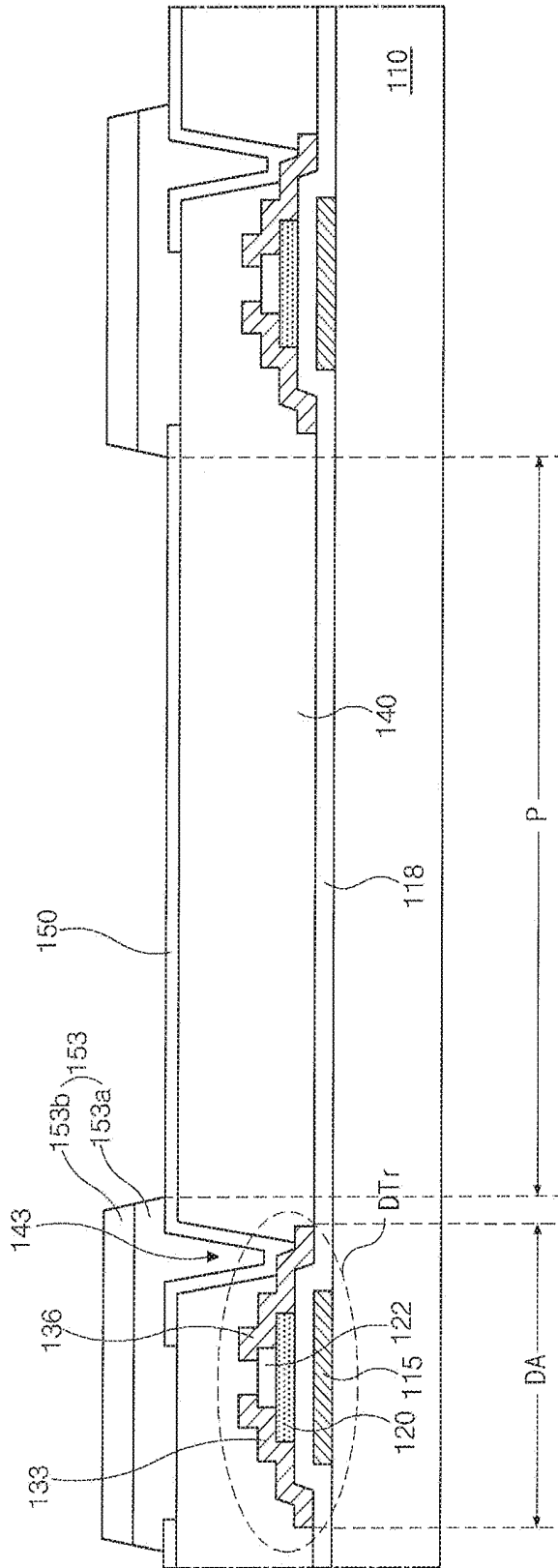

FIG. 7D

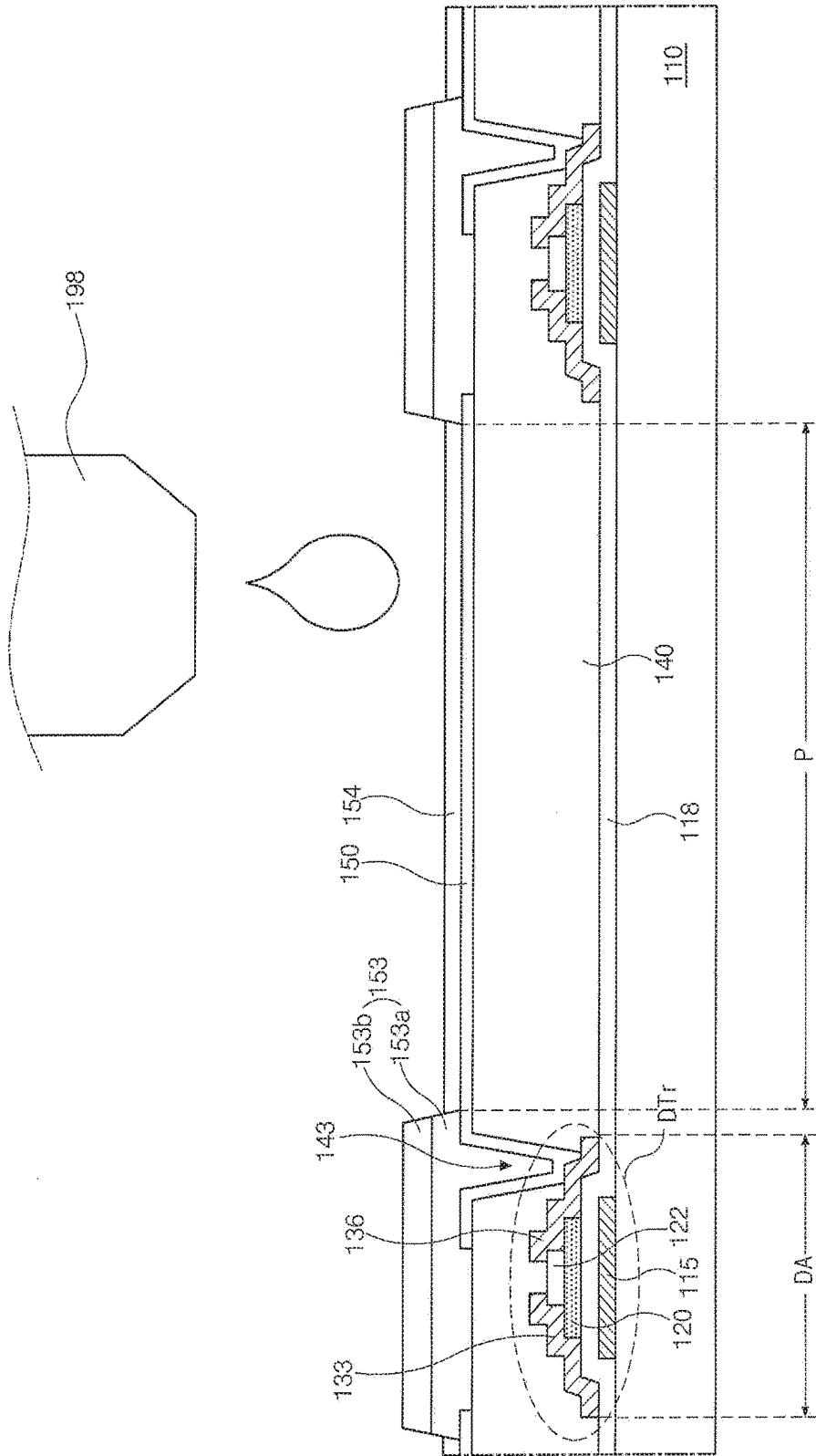

FIG. 7E

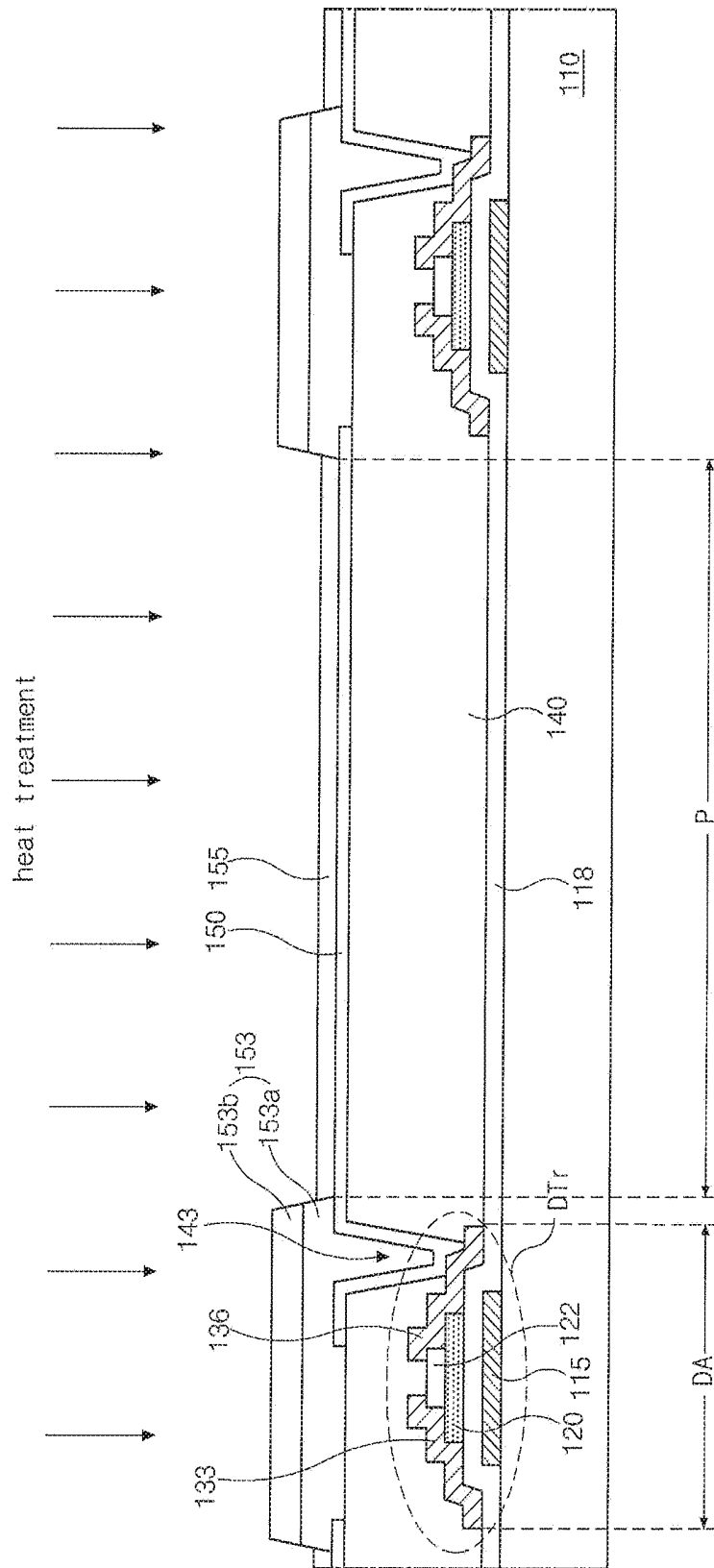

FIG. 7F

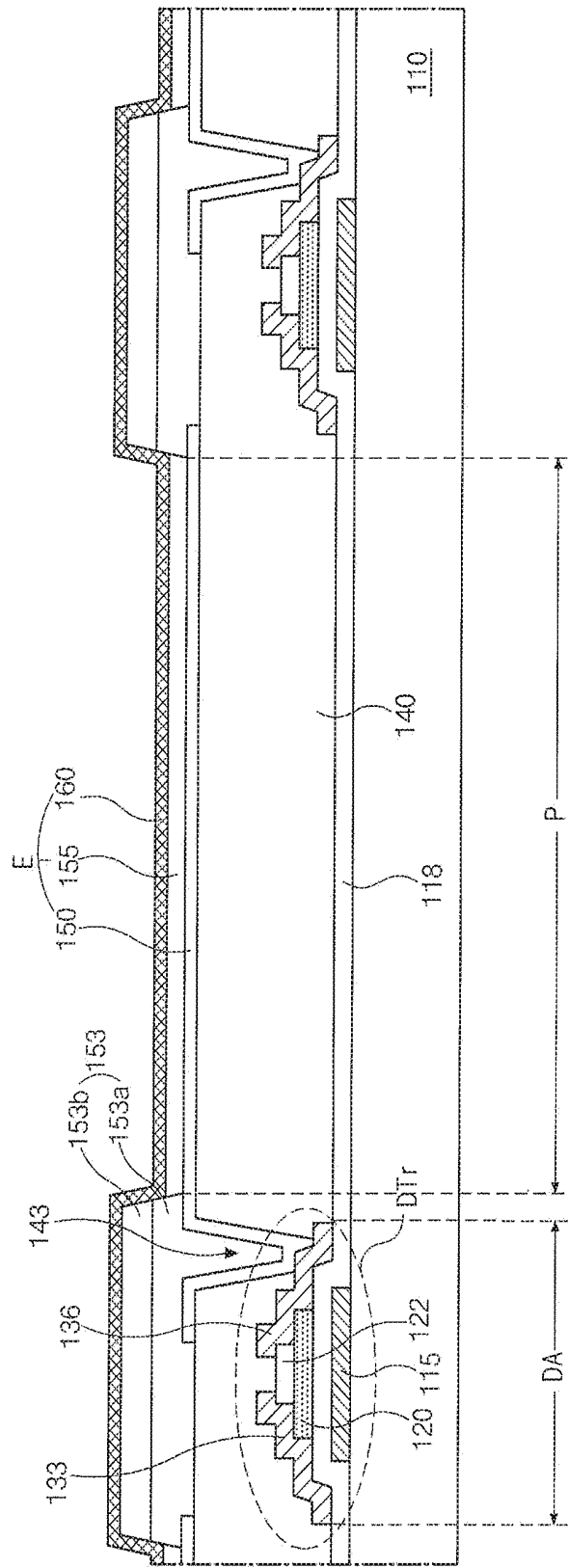

FIG. 7G

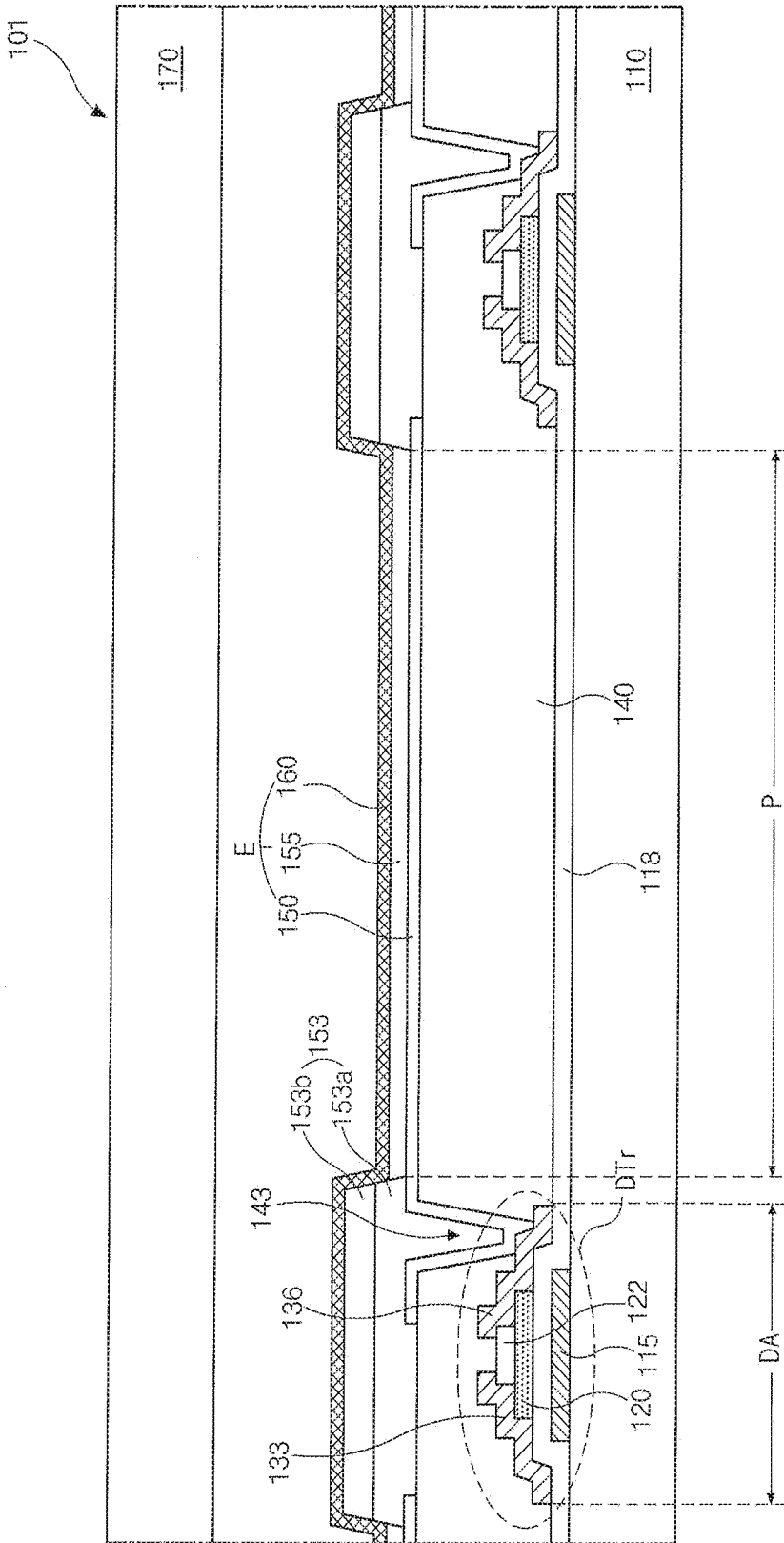

FIG. 7H

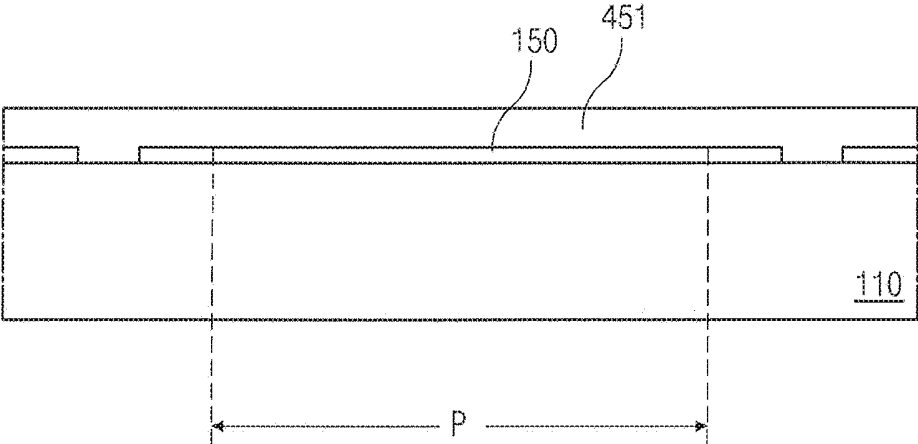

FIG. 8A

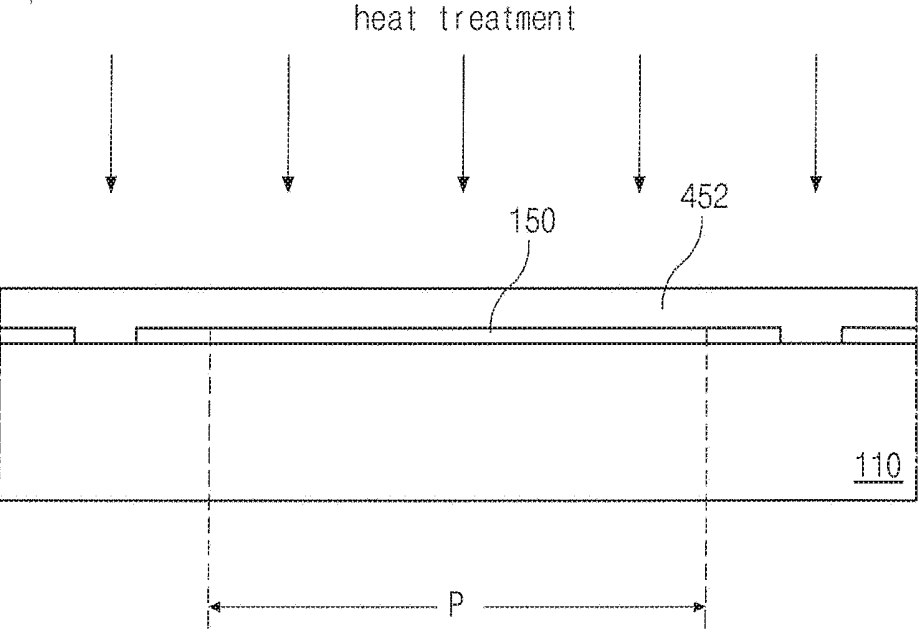

FIG. 8B

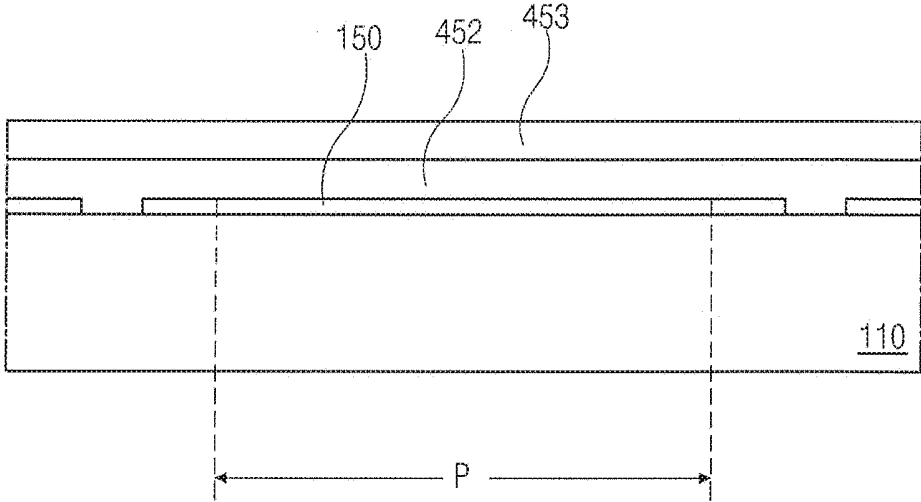

FIG. 8C

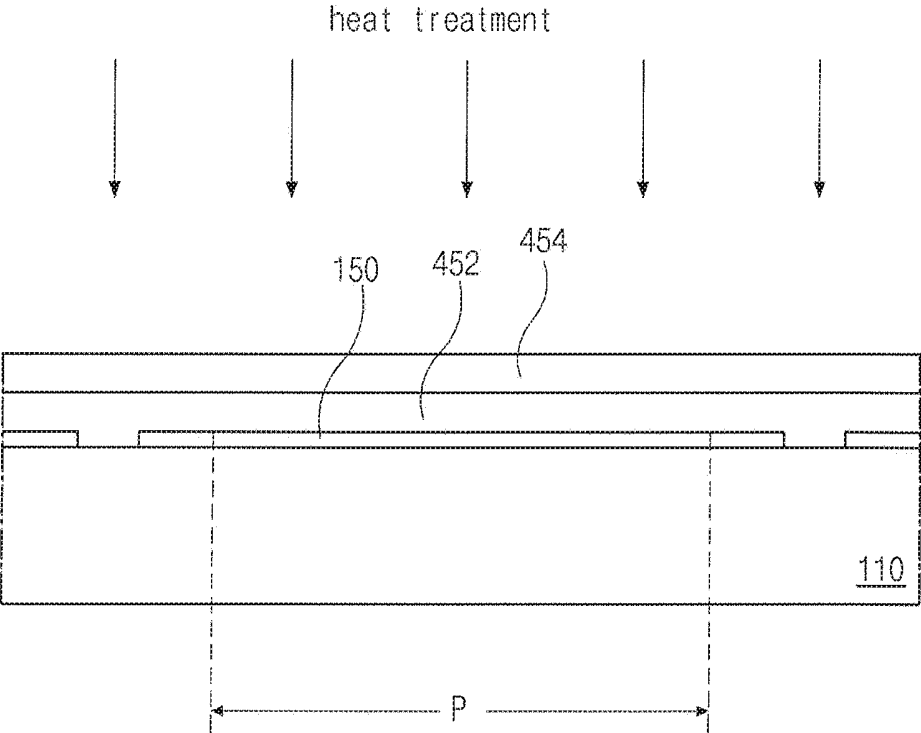

FIG. 8D

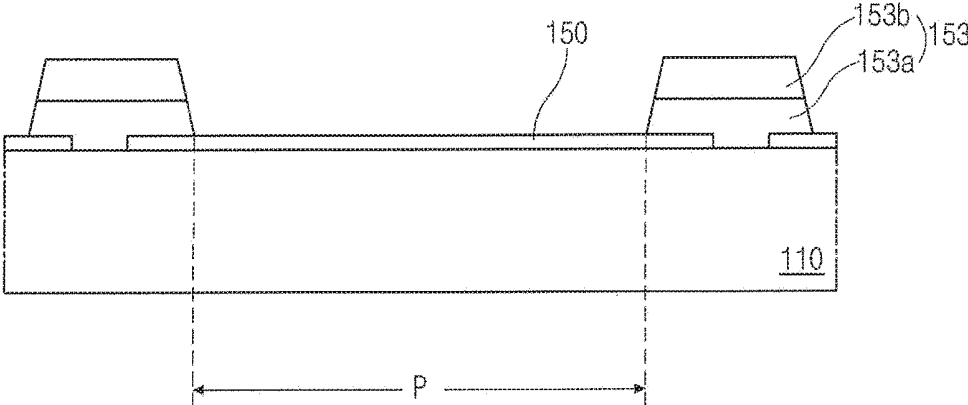

FIG. 8E

**ORGANIC LIGHT EMITTING DIODE
DISPLAY DEVICE AND METHOD OF
FABRICATING THE SAME**

[0001] The present application claims the benefit of Korean Patent Application No. 10-2012-0131546 filed in Korea on Nov. 20, 2012, which is hereby incorporated by reference for all purposes as if fully set forth herein.

BACKGROUND

Field of the Disclosure

[0002] The disclosure relates to an organic light emitting diode (OLED) display device, which may be referred to as an organic electroluminescent display device, and more particularly, to an OLED display device having a bank of a double-layered structure and a method of fabricating the same.

Discussion of the Related Art

[0003] An OLED display device of new flat panel display devices has high brightness and low driving voltage. The OLED display device is a self-emitting type and has excellent view angle characteristics, contrast ratio, a response time, etc.

[0004] Accordingly, the OLED display device is widely used for a television, a monitor, a mobile phone, etc.

[0005] The OLED display device includes an array element and an organic light emitting diode. The array element includes a switching thin film transistor (TFT), which is connected to a gate line and a data line, a driving TFT, which is connected to the switching TFT, and a power line, which is connected to the driving TFT. The organic light emitting diode includes a first electrode, which is connected to the driving TFT, and further includes an organic emitting layer and a second electrode.

[0006] In the OLED display device, light from the organic emitting layer passes through the first electrode or the second electrode to display an image. A top emission type OLED display device, where the light passes through the second electrode, has an advantage in an aperture ratio.

[0007] Generally, the organic emitting layer is formed by a thermal deposition method using a shadow mask. However, the shadow mask sags because the shadow mask becomes larger with an increase in sizes of display devices. As a result, there is a problem in deposition uniformity in the larger display device. In addition, since a shadow effect is generated in the thermal deposition method using the shadow mask, it is very difficult to fabricate a high resolution OLED display device, e.g., above 250 PPI (pixels per inch).

[0008] Accordingly, a new method instead of the thermal deposition method using the shadow mask has been introduced.

[0009] In the new method, a liquid phase organic emitting material is sprayed or dropped in a region surrounded by a wall using an ink jet apparatus or a nozzle-coating apparatus and cured to form the organic emitting layer.

[0010] FIGS. 1A and 1B are schematic cross-sectional views showing an OLED display device in steps of forming an organic emitting layer by spraying or dropping a liquid phase organic emitting material.

[0011] To spray or drop the liquid phase organic emitting material by the ink jet apparatus or the nozzle-coating apparatus, a bank 53, which is formed on the first electrode

50 and surrounds a pixel region P, is required to prevent the liquid phase organic emitting material from flooding into a next pixel region P. Accordingly, as shown in FIG. 1A, the bank 53 is formed on edges of the first electrode 50 before forming the organic emitting layer 55.

[0012] The bank 53 is formed of an organic material including fluorine (F) such that the bank 53 has a hydrophobic property. The hydrophobic bank 53 prevents the organic emitting material, which has a hydrophilic property, from being formed on the bank 53 and flooding into the next pixel region P due to a mis-alignment of the ink jet apparatus or the nozzle-coating apparatus or an excessive amount of the organic emitting material.

[0013] The bank 53 may be formed by a mask process, which includes light-exposing and developing steps after the organic insulating material including fluorine is applied to an entire surface of the substrate 10.

[0014] Next, as shown in FIG. 1B, by spraying or dropping the liquid phase organic emitting material from a head of the ink-jet apparatus or a nozzle of the nozzle-coating apparatus into the pixel region P, which is surrounded by the bank 53, the pixel region P is filled with the organic emitting material. The organic emitting material is dried and cured by heat to form the organic emitting layer 55.

[0015] However, fluorine residues 54 may remain in the pixel region P when the bank 53 is formed, and the fluorine residues 54 may hinder the liquid phase organic emitting material from being spread in the pixel region P when the liquid phase organic emitting material is sprayed or dropped. Accordingly, as shown in FIG. 2, which is a picture showing a part of one pixel region in the related art OLED display device, the organic emitting layer is not formed around the hydrophobic bank, or a portion of the organic emitting layer around the hydrophobic bank has a thinner thickness than portions in other regions. Thus, dark images are displayed in edges of the pixel region. In addition, the OLED display device is degraded fast due to the difference in thicknesses, and the lifetime of the OLED display device is shortened.

SUMMARY

[0016] An organic light emitting diode display device includes a first substrate including a display region, wherein a plurality of pixel regions are defined in the display region; a first electrode over the substrate and in each of the plurality of pixel regions; a bank on edges of the first electrode and surrounding each of the plurality of pixel regions, the bank including a lower layer having a hydrophilic property and an upper layer having a hydrophobic property; an organic emitting layer on the first electrode and in each of the plurality of pixel regions surrounded by the bank; and a second electrode on the organic emitting layer and covering an entire surface of the display region.

[0017] In another aspect, a method of fabricating an organic light emitting diode display device includes forming a first electrode over a first substrate including a display region, which includes a plurality of pixel regions, the first electrode formed in each of the plurality of pixel regions; forming a bank on edges of the first electrode and surrounding each of the plurality of pixel regions, the bank including a lower layer having a hydrophilic property and an upper layer having a hydrophobic property; forming an organic emitting layer on the first electrode and in each of the plurality of pixel regions surrounded by the bank; and

forming a second electrode on the organic emitting layer, the second electrode covering an entire surface of the display region.

[0018] It is to be understood that both the foregoing general description and the following detailed description are exemplary and explanatory and are intended to provide further explanation of the invention as claimed.

BRIEF DESCRIPTION OF THE DRAWINGS

[0019] The accompanying drawings, which are included to provide a further understanding of the invention and are incorporated in and constitute a part of this specification, illustrate embodiments of the invention and together with the description serve to explain the principles of the invention.

[0020] FIGS. 1A and 1B are schematic cross-sectional views showing an OLED display device in steps of forming an organic emitting layer by spraying or dropping a liquid phase organic emitting material.

[0021] FIG. 2 is a picture showing a part of one pixel region in the related art OLED display device.

[0022] FIG. 3 is a circuit diagram of one pixel region of an OLED device.

[0023] FIG. 4 is a schematic cross-sectional view of an OLED display device according to an embodiment of the present invention.

[0024] FIG. 5 is a schematic cross-sectional view of an OLED display device according to one modified embodiment of the present invention.

[0025] FIG. 6 is a schematic cross-sectional view of an OLED display device according to another modified embodiment of the present invention.

[0026] FIGS. 7A to 7H are cross-sectional views showing a fabricating process of an OLED display device according to an embodiment of the present invention.

[0027] FIGS. 8A to 8E are cross-sectional views showing a fabricating process of an OLED display device according to another example of the embodiment of the present invention.

DETAILED DESCRIPTION

[0028] Reference will now be made in detail to the preferred embodiments, examples of which are illustrated in the accompanying drawings.

[0029] FIG. 3 is a circuit diagram of one pixel region of an OLED device.

[0030] As shown in FIG. 3, an OLED display device includes a switching thin film transistor (TFT) STr, a driving TFT DTr, a storage capacitor StgC and an emitting diode E in each pixel region P.

[0031] On a substrate (not shown), a gate line GL along a first direction and a data line DL along a second direction are formed. The gate line GL and the data line DL cross each other to define the pixel region P. A power line PL for providing a source voltage to the emitting diode E is formed to be parallel to and spaced apart from the data line DL.

[0032] The switching TFT STr is connected to the gate and data lines GL and DL, and the driving TFT DTr and the storage capacitor StgC are connected to the switching TFT STr and the power line PL. The emitting diode E is connected to the driving TFT DTr.

[0033] A first electrode of the emitting diode E is connected to a drain electrode of the driving TFT DTr, and a second electrode of the emitting diode E is grounded.

[0034] When the switching TFT STr is turned on by a gate signal applied through the gate line GL, a data signal from the data line DL is applied to the gate electrode of the driving TFT DTr and an electrode of the storage capacitor StgC. When the driving TFT DTr is turned on by the data signal, an electric current is supplied to the emitting diode E from the power line PL. As a result, the emitting diode E emits light. In this case, when the driving TFT DTr is turned on, a level of an electric current applied from the power line PL to the emitting diode E is determined such that the emitting diode E can produce a gray scale. The storage capacitor StgC serves to maintain the voltage of the gate electrode of the driving TFT DTr when the switching TFT STr is turned off. Accordingly, even if the switching TFT STr is turned off, a level of an electric current applied from the power line PL to the emitting diode E is maintained to a next frame.

[0035] FIG. 4 is a schematic cross-sectional view of an OLED display device according to an embodiment of the present invention. For convenience of explanation, a driving area (DA) wherein a driving TFT DTr is formed, a pixel region P where an emitting diode E is formed, and a switching area (not shown) where a switching TFT (not shown) are defined.

[0036] As shown in FIG. 4, an OLED display device 101 of the present invention includes a first substrate 110, where the driving TFT DTr, the switching TFT (not shown) and the emitting diode E are formed, and a second substrate 170 for encapsulation. The second substrate 170 may be an inorganic insulating film or an organic insulating film.

[0037] A gate line (not shown) and a data line (not shown) are formed on the first substrate 110. The gate line and the data line cross each other to define the pixel region P. A power line (not shown) for providing a voltage to the emitting diode E is formed to be parallel to and spaced apart from the data line.

[0038] In each pixel region P, the switching TFT is connected to the gate line and the data line, and the driving TFT DTr and the storage capacitor StgC are connected to the switching TFT and the power line.

[0039] The driving TFT DTr includes a gate electrode 115, a gate insulating layer 118, an oxide semiconductor layer 120, an etch-stopper 122, a source electrode 133 and a drain electrode 136. The gate insulating layer 118 covers the gate electrode 115, and the oxide semiconductor layer 120 is disposed on the gate insulating layer 118. The oxide semiconductor layer 120 corresponds to the gate electrode 115. The etch-stopper 122 covers a center of the oxide semiconductor layer 120. The source electrode 133 and the drain electrode 136 are disposed on the etch-stopper 122 and spaced apart from each other. The source electrode 133 and the drain electrode 136 contact both ends of the oxide semiconductor layer 120, respectively. Although not shown, the switching TFT has substantially the same structure as the driving TFT DTr.

[0040] In FIG. 4, each of the driving TFT DTr and the switching TFT includes the oxide semiconductor layer 120 of an oxide semiconductor material. Alternatively, as shown in FIG. 5, each of the driving TFT DTr and the switching TFT may include a gate electrode 213, a gate insulating layer 218, a semiconductor layer 220 including an active layer 220a of intrinsic amorphous silicon and an ohmic contact

layer **220b** of impurity-doped amorphous silicon, a source electrode **233** and a drain electrode **236**. In FIGS. **4** and **5**, the driving TFT DTr has a bottom gate structure where the gate electrode **115** or **213** is positioned at a lowest layer.

[0041] Meanwhile, each of the driving TFT DTr and the switching TFT may have a top gate structure where the semiconductor layer is positioned at a lowest layer. Namely, as shown in FIG. **6**, each of the driving TFT DTr and the switching TFT may include a semiconductor layer **313**, which includes an active region **313a** of intrinsic polysilicon and impurity-doped regions **313b** at both sides of the active region **313a**, on a first substrate **310**, a gate insulating layer **316**, a gate electrode **320** corresponding to the active region **313a** of the semiconductor layer **313**, an interlayer insulating layer **323** having semiconductor contact holes **325**, which expose the impurity-doped regions **313b** of the semiconductor layer **313**, and source and drain electrodes **333** and **336** respectively connected to the impurity-doped regions **313b** through the semiconductor contact holes **325**.

[0042] The top gate structure TFT requires the interlayer insulating layer **323** in comparison to the bottom gate structure TFT. In the top gate structure TFT, the gate line (not shown) is formed on the gate insulating layer **316**, and the data line (not shown) is formed on the interlayer insulating layer **323**.

[0043] Referring again to FIG. **4**, a passivation layer **140**, which includes a drain contact hole **143** exposing the drain electrode **136** of the driving TFT DTr, is formed over the driving TFT DTr and the switching TFT. For example, the passivation layer **140** may be formed of an organic insulating material, e.g., photo-acryl, to have a flat top surface.

[0044] A first electrode **150**, which contacts the drain electrode **136** of the driving TFT DTr through the drain contact hole **143**, is formed on the passivation layer **140** and separately in each pixel region P.

[0045] The first electrode **150** is formed of a conductive material having a relatively high work function, e.g., about 4.8 eV to 5.2 eV. For example, the first electrode **150** may be formed of a transparent conductive material such as indium-tin-oxide (ITO) to serve as an anode.

[0046] When the first electrode **150** is formed of the transparent conductive material, a reflection layer (not shown) may be formed under the first electrode **150** to increase emission efficiency in a top emission type OLED display device. For example, the reflection layer may be formed of a metallic material, such as aluminum (Al) or Al alloy such as AlNd, having a relatively high reflectivity.

[0047] With the reflection layer, the light from an organic emitting layer **155**, which is formed on the first electrode **150**, is reflected by the reflection layer such that the emission efficiency is increased. As a result, the OLED display device has an improved brightness property.

[0048] A bank **153** having a double-layered structure, which includes a lower layer **153a** and an upper layer **153b**, is formed on the first electrode **150** along boundaries of the pixel region P. The bank **153** overlaps edges of the first electrode **150** such that a center of the first electrode **150** is exposed by the bank **153**.

[0049] The lower layer **153a** of the bank **153** has a hydrophilic property, and the upper layer **153b** has a hydrophobic property.

[0050] The organic emitting layer **155** is formed in each pixel region P surrounded by the bank **153** having the

double-layered structure. The organic emitting layer **155** includes red, green and blue emitting materials in respective pixel regions P.

[0051] The organic emitting layer **155** is formed by forming an organic emitting material layer and curing the organic emitting material layer. The organic emitting material layer is formed by coating, i.e., spraying or dropping a liquid phase organic emitting material by an ink jet apparatus or a nozzle-coating apparatus.

[0052] In the OLED display device **101** including the bank **153** of a double-layered structure, which includes the lower layer **153a** having the hydrophilic property and the upper layer **153b** having the hydrophobic property, hydrophobic residues hardly remain on the first electrode **150** after patterning the bank **153**, and the liquid phase organic emitting material can be spread well in the pixel region P surrounded by the bank **153** when the material is sprayed or dropped.

[0053] Furthermore, since force drawing the organic emitting material is generated due to the lower layer **153a** having the hydrophobic property, the organic emitting material is spread better, and the organic emitting layer **155** is formed in edges of the pixel region P adjacent to the bank **153**. Accordingly, the organic emitting layer **155** has a uniform thickness in the pixel region P due to the bank **153** having the double-layered structure.

[0054] FIG. **4** shows a single-layered organic emitting layer **155**. Alternatively, to improve emission efficiency, the organic emitting layer **155** may have a multi-layered structure. For example, the organic emitting layer **155** may include a hole injecting layer, a hole transporting layer, an emitting material layer, an electron transporting layer and an electron injecting layer stacked on the first electrode **150** as an anode. The organic emitting layer **155** may be a quadruple-layered structure of a hole transporting layer, an emitting material layer, an electron transporting layer and an electron injecting layer or a triple-layered structure of a hole transporting layer, an emitting material layer and an electron transporting layer.

[0055] A second electrode **160** is formed on the organic emitting layer **155** and covers an entire surface of a display region of the first substrate **110**. The second electrode **160** is formed of a metallic material having a relatively low work function, e.g., Al, Al alloy such as AlNd, silver (Ag), magnesium (Mg), gold (Au), or Al—Mg alloy (AlMg). The second electrode **160** serves as a cathode.

[0056] The first electrode **150**, the organic emitting layer **155** and the second electrode **160** constitute the emitting diode E.

[0057] A seal pattern (not shown) of a sealant or a frit material is formed on edges of the first substrate **110** or the second substrate **170**. The first and second substrates **110** and **170** are attached using the seal pattern. A space between the first and second substrates **110** and **170** has a vacuum condition or an inert gas condition. The second substrate **170** may be a flexible plastic substrate or a glass substrate.

[0058] Alternatively, the second substrate **170** may be a film contacting the second electrode **160**. In this instance, the film-type second substrate is attached to the second electrode **160** by an adhesive layer.

[0059] In addition, an organic insulating film or an inorganic insulating film may be formed on the second electrode **160** as a capping layer. In this instance, the organic insulat-

ing film or the inorganic insulating film serves as the encapsulation film without the second substrate 170.

[0060] Hereinafter, a method of fabricating the OLED display device is explained with reference to drawings.

[0061] FIGS. 7A to 7H are cross-sectional views showing a fabricating process of an OLED display device according to an embodiment of the present invention. The explanation is focused on a bank having a double-layered structure.

[0062] As shown in FIG. 7A, the gate line (not shown), the data line (not shown) and the power line (not shown) are formed on the first substrate 110. In addition, the switching TFT (not shown) connected to the gate and data lines and the driving TFT DTr connected to the switching TFT and the power line are formed in the switching area (not shown) and in the driving area DA, respectively.

[0063] As explained above, each of the switching TFT and the driving TFT DTr has a bottom gate type TFT including the gate electrode 115 of FIG. 4 or 213 of FIG. 5 as a lowest layer or a top gate type TFT including the semiconductor layer 313 of FIG. 6 as a lowest layer. The bottom gate type TFT includes the oxide semiconductor layer 120 of FIG. 4 or the amorphous silicon semiconductor layer 220 of FIG. 5 including the active layer 220a and the ohmic contact layer 220b, and the top gate type TFT includes the poly-silicon semiconductor layer 313 of FIG. 6.

[0064] Here, the switching TFT and the driving TFT DTr may be the bottom gate type TFT including an oxide semiconductor layer. Therefore, the gate electrode 115 of the driving TFT DTr is formed on the first substrate 110, the gate insulating layer 118 is formed on the gate electrode 115, and the oxide semiconductor layer 120 is formed on the gate insulating layer 118 corresponding to the gate electrode 115. The etch-stopper 122 is formed on the oxide semiconductor layer 120 and covers the center of the oxide semiconductor layer 120. The source and drain electrodes 133 and 136 are formed on the etch-stopper 122 and spaced apart from each other.

[0065] Next, an organic insulating material, e.g., photoacryl, is coated over the switching TFT and the driving TFT DTr and is patterned to form the passivation layer 140 having a flat top surface and including the drain contact hole 143. The drain electrode 136 of the driving TFT DTr is exposed through the drain contact hole 143.

[0066] Next, a transparent conductive material, which has a relatively high work function, is deposited on the passivation layer 140 and patterned to form the first electrode 150. The first electrode 150 contacts the drain electrode 136 of the driving TFT DTr through the drain contact hole 143 and is separated in each pixel region P. For example, the transparent conductive material may be indium tin oxide (ITO).

[0067] Meanwhile, as explained above, the reflection layer (not shown), which includes Al or Al alloy such as AlNd, may be formed under the first electrode 150 and on the passivation layer 140. The reflection layer may be formed by the same mask process as the first electrode 150.

[0068] Next, as shown in FIG. 7B, a bank material layer 151 is formed on the first electrode 150 and the passivation layer 140. For example, the bank material layer 151 may be formed by applying a bank material with a coating apparatus such as a spin-coating apparatus, a bar-coating apparatus, or a slit-coating apparatus. The bank material may be a liquid phase and include a low molecular substance having a hydrophobic property and a high molecular substance hav-

ing a hydrophilic property mixed at an optimal content ratio. The bank material may also have a photosensitive property and a phase separation property. For example, the low molecular substance may have a molecular weight of several tens to several thousand, more beneficially, more than 10 and under 10,000 and include fluorine (F). The high molecular substance may have a molecular weight of ten thousand to several million, more beneficially, more than 15,000 and less than 1,000,000. The high molecular substance may include a photosensitive polymer, for example, polyimide or acryl.

[0069] Next, in FIG. 7C, a heat-treatment process is performed to the bank material layer 151 of FIG. 7B. The heat-treatment process may be a soft-baking process. For example, the bank material layer 151 of FIG. 7B may be heat-treated in an oven or furnace having an inside temperature of 60 degrees of Celsius to 100 degrees of Celsius for several seconds to several hundred seconds or may be heat-treated on a hot plate having a surface temperature of 60 degrees of Celsius to 100 degrees of Celsius for several seconds to several hundred seconds.

[0070] The bank material layer 151 of FIG. 7B is dried and cured by heat through the soft-baking process, and molecules actively move due to the heat. Thus, phase separation occurs. More particularly, relatively heavy molecules having molecular weights of more than 15,000 move to a lower portion of the bank material layer 151 of FIG. 7B, and relatively light molecules having molecular weights under 10,000 move to an upper portion of the bank material layer 151 of FIG. 7B.

[0071] Meanwhile, solvents and moisture in the bank material layer 151 of FIG. 7B are removed by the heat during the soft-baking process, and the bank layer 152 having the double-layered structure, which includes a first layer 152a of a hydrophilic low molecular substance and a second layer 152b of a hydrophobic high molecular substance, is formed.

[0072] In FIG. 7D, an exposing mask (not shown) including a transmitting region and a blocking region is disposed over the bank material layer 152 of FIG. 7C, and an exposing process to the bank material layer 152 of FIG. 7C is performed using the exposing mask without an additional photoresist layer.

[0073] Here, the bank material layer 152 of FIG. 7C is shown to have a negative type photosensitive property where an exposed portion of the bank material layer 152 of FIG. 7C remains after a developing process. Alternatively, the bank material layer 152 of FIG. 7C may have a positive type photosensitive property, and at this time, a position of the transmitting region and the blocking region is switched.

[0074] Next, the bank 153 including the lower layer 153a and the upper layer 153b is formed by developing the bank layer 152 of FIG. 7C exposed to light. In this instance, an exposed portion of the bank layer 152 of FIG. 7C corresponding to the transmitting region of the exposing mask remains, and a non-exposed portion of the bank layer 152 of FIG. 7C corresponding to the blocking region of the exposing mask is removed by the developing process.

[0075] Here, the first layer 152a of the bank layer 152 of FIG. 7C contacting the first electrode 150 does not include fluorine (F), and the second layer 152b of the bank layer 152 of FIG. 7C including fluorine (F) does not contact the first electrode 150. Accordingly, after the developing process, fluorine residues may be completely removed or the mini-

mum of fluorine residues may remain on the surface of the first electrode **150** even if the fluorine residues are not completely removed.

[0076] The bank **153** including the lower layer **153a** and the upper layer **153b** corresponds to the boundaries of the pixel region P and overlaps the edges of the first electrode **150**. The lower layer **153a** of the bank **153** has a hydrophilic property, and the upper layer **153b** of the bank **153** has a hydrophobic property.

[0077] In the meantime, the bank **153** having the double-layered structure may be formed using a photosensitive material having a hydrophilic property and a photosensitive material having a hydrophobic property. This will be explained as another example of the embodiment with reference to FIGS. **8A** to **8E**. FIGS. **8A** to **8E** are cross-sectional views showing a fabricating process of an OLED display device according to another example of the embodiment of the present invention. In FIGS. **8A** to **8E**, the switching and driving TFTs and layers under the first electrode **150** are omitted, and figures show cross-sections of the OLED display device in steps of forming a bank having a double-layered structure.

[0078] As shown in FIG. **8A**, a first bank material layer **451** is formed on the first electrode **150** all over the first substrate **110**. The first bank material layer **451** may be formed by applying a photosensitive material having a hydrophilic property, for example, polyimide or acryl, using a coating apparatus (not shown).

[0079] Next, in FIG. **8B**, a first bank layer **452** having the hydrophilic property is formed by drying and curing the first bank material layer **451** of FIG. **8A** through a heat-treatment process, for example, the soft-baking process as mentioned above.

[0080] The photosensitive material having the hydrophilic property may include a high molecular substance or a low molecular substance.

[0081] In FIG. **8C**, a second bank material layer **453** is formed on the first bank layer **452**. The second bank material layer **453** may be formed by applying a photosensitive material having a hydrophobic property, for example, acryl including fluorine (F), using a coating apparatus (not shown).

[0082] Next, in FIG. **8D**, a second bank layer **454** having the hydrophobic property is formed by drying and curing the second bank material layer **453** of FIG. **8C** through a heat-treatment process, for example, the soft-baking process as mentioned above. The photosensitive material having the hydrophobic property may include a high molecular substance or a low molecular substance.

[0083] Since the first bank layer **452** having the hydrophilic property is already cured, molecules of the photosensitive material having the hydrophobic property do not move into the first bank layer **452** during the soft-baking process of the second bank material layer **453** of FIG. **8C**.

[0084] In FIG. **8E**, the first and second bank layers **452** and **454** of FIG. **8D** are exposed to light through an exposing mask (not shown) and developed, thereby forming the bank **153** having a double-layered structure of the hydrophilic lower layer **153a** and the hydrophobic upper layer **153b**, which is the same as that in FIG. **7D**.

[0085] In another example of the embodiment of the present invention, there is no hydrophobic residue on the first electrode **150**, and thus an organic emitting material, which will be sprayed or dropped, is spread well.

[0086] In the meantime, as shown in FIG. **7E**, after forming the bank **153** having the double-layered structure, an organic emitting material layer **154** is formed on the first electrode **150** by spraying or dropping a liquid phase organic emitting material in a region surrounded by the bank **153**,

i.e., in the pixel region P, with an ink jet apparatus or a nozzle-coating apparatus **198**.

[0087] Even if the organic emitting material is sprayed or dropped on the upper layer **153b** because of a mis-alignment of the ink jet apparatus or the nozzle-coating apparatus **198**, the organic emitting material is concentrated into a center of the pixel region P because the upper layer **153b** has the hydrophobic property. In addition, even if an excessive amount of the organic emitting material is sprayed or dropped, the organic emitting material does not flow over the upper layer **153b** due to the hydrophobic property of the upper layer **153b**.

[0088] Furthermore, since the lower layer **153a** of the bank **153** has the hydrophilic property, force drawing the liquid phase organic emitting material is generated from sides of the lower layer **153a** of the bank **153**, and the liquid phase organic emitting material is spread well on the first electrode **150** to contact the sides of the lower layer **153a** of the bank **153**.

[0089] Next, as shown in FIG. **7F**, by performing a curing process, solvents and moisture in the organic emitting material layer **154** of FIG. **7E** are removed such that the organic emitting layer **155** is formed in the pixel region P.

[0090] As mentioned above, since the organic emitting layer **155** contacts the sides of the lower layer **153a** of the bank **153**, the organic emitting layer **155** is also formed around the bank **153** and has a substantially uniform thickness in the pixel region P.

[0091] Here, the organic emitting layer **155** has a single-layered structure. Alternatively, to improve emission efficiency, the organic emitting layer **155** may have a multi-layered structure, which may be formed by the same method as that of the single-layered structure or may be formed in an entire surface of a display region by a deposition method. For example, the organic emitting layer **155** may include a hole injecting layer, a hole transporting layer, an emitting material layer, an electron transporting layer and an electron injecting layer stacked on the first electrode **150** as an anode. The organic emitting layer **155** may be a quadruple-layered structure of the hole transporting layer, the emitting material layer, the electron transporting layer and an electron injecting layer or a triple-layered structure of the hole transporting layer, the emitting material layer and the electron transporting layer.

[0092] Next, as shown in FIG. **7G**, the second electrode **160** is formed on the organic emitting layer **155** by depositing a metallic material having a relatively low work function. The second electrode **160** is formed on an entire surface of the display region. The metallic material includes at least one of Al, Al alloy such as AlNd, Ag, Mg, Au and AlMg.

[0093] As explained above, the first electrode **150**, the organic emitting layer **155** and the second electrode **160** constitute the emitting diode E.

[0094] Next, as shown in FIG. **7H**, after forming a seal pattern (not shown) on edges of the first substrate **110** or the second substrate **170**, the first and second substrates **110** and **170** are attached under a vacuum condition or an inert gas condition such that the OLED display device is fabricated. Alternatively, a paste seal (not shown), which is formed of a fit material, an organic insulating material or a polymer material having transparent and adhesive properties is formed over an entire surface of the first substrate **110**, and then the first and second substrates **110** and **170** are attached.

As explained above, instead of the second substrate **170**, an inorganic insulating film or an organic insulating film may be used for an encapsulation and may be attached by an adhesive layer.

[0095] In the OLED display device of the invention, since the bank has the double-layered structure of the hydrophilic lower layer and the hydrophobic upper layer, the hydrophobic residues hardly remain on the first electrode after forming the bank by patterning the bank layer. Therefore, the liquid phase organic emitting material is spread well in the pixel region surrounded by the bank when it is sprayed or dropped.

[0096] Moreover, the organic emitting material is spread better due to the force drawing the organic emitting material from the lower layer of the bank because the lower layer of the bank has the hydrophilic property, and the organic emitting layer is formed in the boundaries of the pixel region P adjacent to the bank.

[0097] Accordingly, the organic emitting layer has a uniform thickness in the pixel region, and the organic emitting layer is prevented from being degraded, thereby lengthening lifetime of the device.

[0098] It will be apparent to those skilled in the art that various modifications and variations can be made in the present invention without departing from the spirit or scope of the invention. Thus, it is intended that the present invention cover the modifications and variations of this invention provided they come within the scope of the appended claims and their equivalents.

1. An organic light emitting diode display device, comprising:

a first substrate including a display region, wherein a plurality of pixel regions are defined in the display region;

a first electrode over the substrate and in each of the plurality of pixel regions;

a bank on edges of the first electrode and surrounding each of the plurality of pixel regions, the bank including a lower layer having a hydrophilic property and an upper layer having a hydrophobic property;

an organic emitting layer on the first electrode and in each of the plurality of pixel regions surrounded by the bank; and

a second electrode on the organic emitting layer and covering an entire surface of the display region.

2. The device according to claim 1, wherein the lower layer having the hydrophilic property includes a high molecular substance having a molecular weight of more than 15,000, and the upper layer having the hydrophobic property includes a low molecular substance having a molecular weight under 10,000.

3. The device according to claim 2, wherein the high molecular substance includes polyimide or acryl, and the upper layer includes fluorine.

4. The device according to claim 1, further comprising:

a switching thin film transistor and a driving thin film transistor in each of the plurality of pixel regions and under the first electrode; and

a passivation layer covering the switching thin film transistor and the driving thin film transistor and exposing a drain electrode of the driving thin film transistor, wherein the first electrode is disposed on the passivation layer and contacts the drain electrode of the driving thin film transistor.

5. The device according to claim 4, further comprising one of a second substrate facing the first substrate or an encapsulation film contacting the second electrode.

6.-11. (canceled)

* * * * *

专利名称(译)	有机发光二极管显示装置及其制造方法		
公开(公告)号	US20180254310A1	公开(公告)日	2018-09-06
申请号	US15/974496	申请日	2018-05-08
[标]申请(专利权)人(译)	乐金显示有限公司		
申请(专利权)人(译)	LG DISPLAY CO. , LTD.		
当前申请(专利权)人(译)	LG DISPLAY CO. , LTD.		
[标]发明人	JEON HONG MYEONG LEE JAE KI SEO HWANG UN LEE A RYOUNG LEE GEUM YOUNG		
发明人	JEON, HONG-MYEONG LEE, JAE-KI SEO, HWANG-UN LEE, A-RYOUNG LEE, GEUM-YOUNG		
IPC分类号	H01L27/32 H01L51/56 H01L51/00		
CPC分类号	H01L27/326 H01L27/3262 H01L27/3258 H01L27/3246 H01L51/0005 H01L51/56 H01L2227/323		
优先权	1020120131546 2012-11-20 KR		
其他公开文献	US10651249		
外部链接	Espacenet USPTO		

摘要(译)

一种有机发光二极管显示装置，包括：第一基板，包括显示区域；其中，多个像素区域限定在显示区域中；基板上方和多个像素区域中的每个像素区域中的第一电极；在所述第一电极的边缘上并且围绕所述多个像素区域中的每一个的堤岸，所述堤岸包括具有亲水性的下层和具有疏水性的上层；第一电极上和由堤岸围绕的多个像素区域中的每个像素区域中的有机发光层；第二电极位于有机发光层上并覆盖显示区域的整个表面。

